

Boiler is a device which is used for generating steam. A boiler is an enclosed chamber, the pressure of the steam in a boiler is always above atmosphere. In a boiler steam is produced by the conversion of water. The generated steam is supplied to steam engines or turbines for power generation.

The steam thus generated is used for,

(i) Power Generation:-

Mechanical work or electric power may be generated by expanding steam in the steam engine or steam turbine.

(ii) Heating:-

The steam is utilised for heating the residential and industrial buildings in cold weather and for producing hot water for hot water supply.

(iii) Utilization of steam for industrial process:-

The generated steam may also be used for process work in cotton mills, sugar factories and chemical industries and for heating purposes.

Important terms for steam boilers:-

(i) Boiler shell:-

Boiler is made up of steel plates, they are bent into cylindrical form and riveted or welded together. It is closed by end plates, the boiler shell should have sufficient capacity to contain water & steam.

(ii) Combustion chamber:-

It is provided below the boiler shell. It is meant for burning fuel in order to produce steam from the water contained in the shell.

### (iii) Grate :-

It is a platform in the combustion chamber, upon which fuel like coal, wood is burnt. The grate generally consists of cast iron bars which are spaced apart so that air which is required for combustion can pass through them.

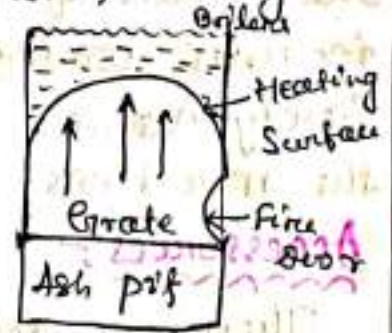

### (iv) Grate Surface :-

The surface area of the grate, over which the fuel is placed is called grate surface.

### (v) Furnace :-

It is provided above the grate and below the boiler shell, in which the fuel is actually burnt. The furnace is also called as fire box.

### (vi) Heating Surface :-

It is that part of boiler surface, which is exposed to the fire (or hot gases from the fire).

### (vii) Water space and steam space :-

Water space is that volume of the boiler which is occupied by water. Remaining space is called steam space because it is needed for storage of steam in the boiler until it is drawn off through the steam pipe.

### (viii) Flue gases :-

Flue gases are hot gases produced due to combustion of fuel in the boiler surface. Flue gas usually contains water vapour ( $H_2O$ ),  $CO_2$ ,  $CO$  &  $N_2$ . Flue gas includes complete and incomplete products of combustion of fuels.

### (iv) Mountings :-

These are the fittings which are mounted on the boiler for its proper functioning. The fittings includes water level indicator, pressure gauge, Safety valve. A boiler cannot function without the mountings.

### (v) Accessories :-

They are devices and integral part of a boiler. They include superheater, economiser, feed pump etc. The accessories helps in controlling and running the boiler efficiently.

### CLASSIFICATION OF BOILERS :-

A boiler essentially consists of a furnace, where the fuel is burnt in order to supply heat. The combustible matters in a fuel after combustion form a gas which is called flue gas. The main classifications of boilers are.

#### ① According to the contents in the tube

The steam boilers, according to the contents in the tube may be fire tube or smoke tube boiler and water tube boiler.

If the hot flue gases from the boiler furnace flow through the tubes and water surrounds these tubes then the boiler is known as fire tube boiler. Examples of fire tube boilers are Cochran, Cornish, Lancashire, Locomotive boilers etc.

If the water flows through the tubes which are surrounded by the fire or hot flue gases from the boiler furnace, then the boiler is

apart. Flat bells are made of leather

known as water tube boiler, Example of water tube boilers are Babcock and Wilcox, Stirling etc.

### According to the Use:-

The steam boiler according to their use, maybe classified as (i) stationary (ii) mobile boiler.

If the boiler are used at one place only, they are called stationary boilers. Such type of boilers are used in power plants and industrial work. Example Lancashire.

The mobile steam boilers are those which move from the one place to another place. These boilers are locomotive and marine boilers.

### According to the position of furnace:-

According to the position of furnace, boilers are classified as (i) internally fired boilers and (ii) Externally fired boilers.

The furnace region (space in which combustion of fuel takes place) is provided inside the boiler shell. It is completely surrounded by water cooled surfaces, most of the fire tube steam boilers are internally fired. Examples of internally fired boilers are Lancashire, locomotive and Scotch boilers.

If the furnace is arranged outside the region of boiling water, the boiler is known as externally fired boiler, Examples. Babcock & Wilcox boilers.

### According to the axis of the shell:-

The steam boilers, according to the axis of the shell, may be classified as (i) Vertical & (ii) Horizontal boiler.

In case of vertical steam boilers, the axis of the shell is vertical, Cochran boiler is an example of this.

In case of horizontal steam boiler the axis of the shell is horizontal, Lancashire, Locomotive and Babcox and Wilcox boiler are examples of the horizontal boilers.

### ⑤ According to the method of circulation of water and steam:-

It may be classified as ① Natural circulation boiler & ② forced circulation boiler.

If the circulation of  $H_2O$  in the boiler is due to convection currents produced by heat the boilers are known as natural circulation boilers. Examples: Babcox & Wilcox boiler.

But in case of forced circulation boiler, there is a forced circulation of water by a centrifugal pump driven by some external power. Example, Lamont, Benson boiler.

### ⑥ According to the number of tubes:-

According to the number of tubes, boilers are classified as single tube boiler & multi tube boiler.

In case of single tube boiler there is only one fire tube or water tube, simple vertical boiler Cornish boiler are single tube, because it possesses only one fire tube.

But in case of multitube boiler there are two or more fire tubes or water tubes each. Babcox and Wilcox, Locomotive boilers are multitube boiler.

## BABCOCK AND WILCOX

### BOILER

Babcock and Wilcox boiler is a horizontally straight tube externally fired, natural circulation, stationary, water tube boiler. This boiler is of high capacity type & produces steam up to a pressure of varies from 11.5 to 17.5 bars at a steaming rate or evaporating of capacity of about 20,000 to 40,000 kg/hr. In this water tube boiler the water is inside the tubes and hot gases flow over the tubes. These types of boilers are used both for large as well as small thermal power stations for generating large quantities of steam at high pressure.

### Construction & Working Principle:-

Babcock & Wilcox type of boiler generally consists of a horizontal drum 'A', which is connected with two vessel 'C', called headers by means of two inclined tubes B & B'. [Headers means which is supplying fluids to a no. of tubes or passage or connecting them in parallel]. The larger inclined tube is called Riser (B) and shorter inclined tube 'B' is called down-take. The two headers are connected to each other by means of a no. of tubes (WT) called water tubes. These tubes are inclined at 15° to horizontal.

A vessel MB called mud box is fitted at the bottom of the down-take header 'B'. The sediments of feed water in the boiler settle

in the mud box and are taken out from time to time by opening a valve (V) called blow-off valve. coal flows from coal bunker to a mechanical stoker Ms from where it is led to the grate.

Generally, the runner, riser headers inclined water tubes and a part of the horizontal drum is filled up with water and flue gases from the grate of the boiler furnace circulate and these tubes. Actually the headers are made curved so that all the water tubes are exposed properly in hot gases without any interference due to overlapping of some tubes by others.

When the boiler is put into action by igniting the coal over the grate. The  $H_2O$  in the left hand position of the tubes which is just above the grate becomes first heated and thus being comparatively lighter than  $H_2O$  in the right hand position of the tubes tends to rise to the drum through the riser. The cold  $H_2O$  from the right hand portions of the tubes and from the drum then tends to take their place. Thus  $H_2O$  carries down to the  $H_2O$  tubes through the runner and rises up through the riser. In this way a circulation of  $H_2O$  goes on from the drum to the  $H_2O$  tubes through the runner and riser. The flue gases however are finally through

the opening is to a chimney from where they escape into atmosphere.

**BABCOCK AND WILCOX BOILER**

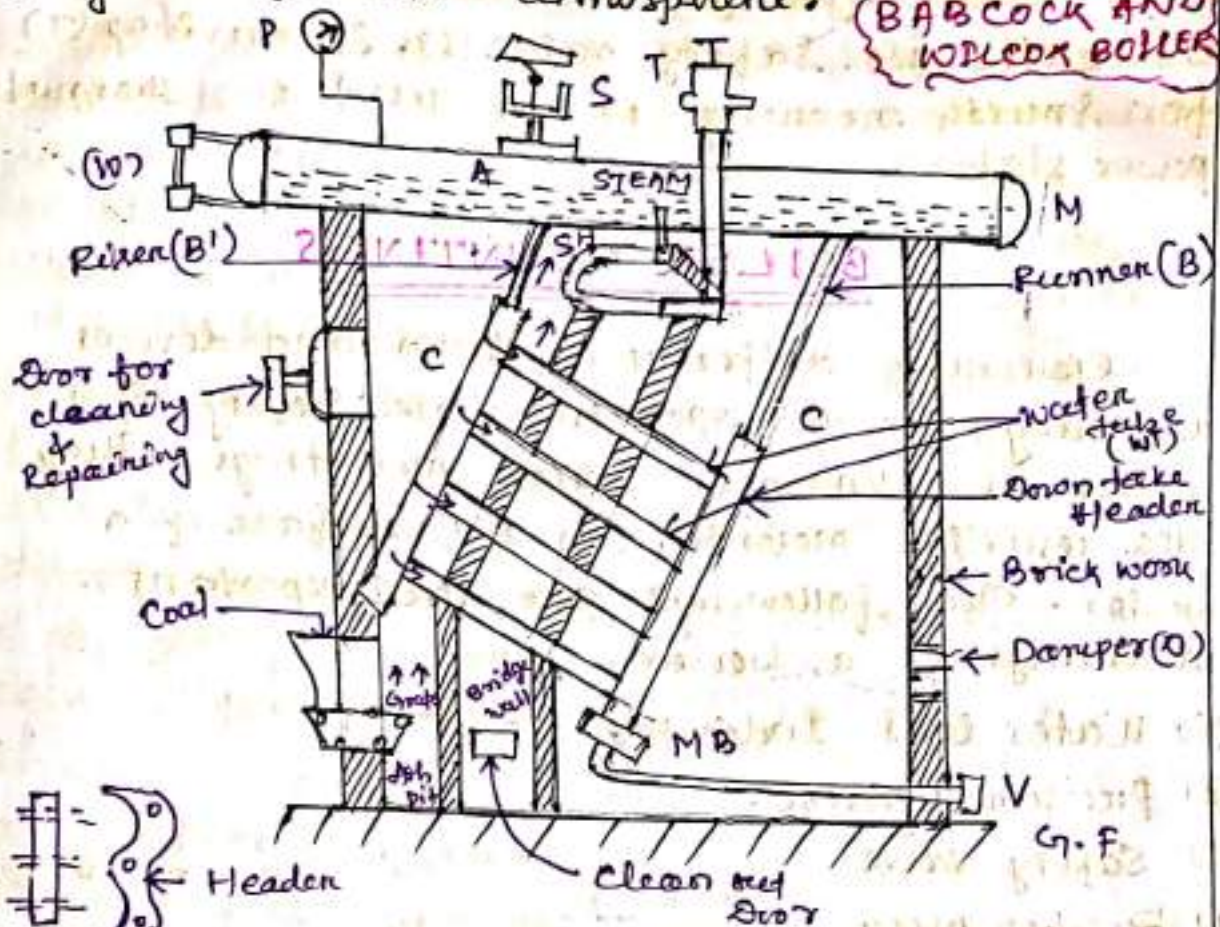

Due to continuous flow of flue gases surrounding the  $H_2O$  tubes. the circulating  $H_2O$  becomes more and more heated and ultimately it reaches its boiling point temp. and steam begins to be produced. The steam is passed through a superheater (SH) where it is further heated by the outgoing flue gases and thus it becomes superheated. The superheated steam is finally led out of the boiler through the steam stop valve (T).

A damper of clean out doors are provided in the wall of fire brick end here for clearing the internal walls and fittings.



The Babcock and Wilcox boiler is fitted with usual fittings such as water level indicator (W), safety valve (S), steam stop (T) for smooth running. It is used in thermal power stations.

## BOILER MOUNTINGS

Generally different fittings and devices necessary for the operation and safety of a boiler are known as boiler mountings. They are usually mounted on the surface of a boiler. The following are the important mountings of a boiler.

- 1) Water level Indicator
- 2) Pressure gauge
- 3) Safety valve
- 4) Fusible plug
- 5) Steam stop valve
- 6) Blow off valve or blow down cock
- 7) Feed check valve

### 1. Water level indicator:-

Function:- Water level indicator is an important appliance used to indicate level of water inside the boiler to the observer. Usually two water level indicators are fitted in front of the boiler. It shows the level of water in the boiler drum and warns the operator if by chance, the water level goes below a fixed mark so that corrective action may be taken in time to avoid any accident.

## Working Principle:-

Generally water level indicator used in low pressure boiler. It consists of a vertical hard glass tube. It is fitted with two gun metal tubes A & B. The tube A connects the steam space of the boiler with the glass tube and the tube B connects the water space of the boiler with the glass tube.

It consists of three cocks.

The tube A is provided with a cock 'S' called steam cock and the tube B is fitted with another cock 'W' called water cock.

In addition to these cocks a third cock 'D' called drain cock is used to drain out the water from the glass tube at intervals to ascertain that the steam and water cock are clear in operation. The glass tube is generally protected with a shield.

For the observation of the water level in the boiler, the steam and water cocks are opened and drain cock is closed. In this case the handles are placed in vertical position as shown in the figure. The steam enters from the upper end of the glass tube and water enters from the lower tube. So the water level inside the boiler will be same as seen in the glass tube.

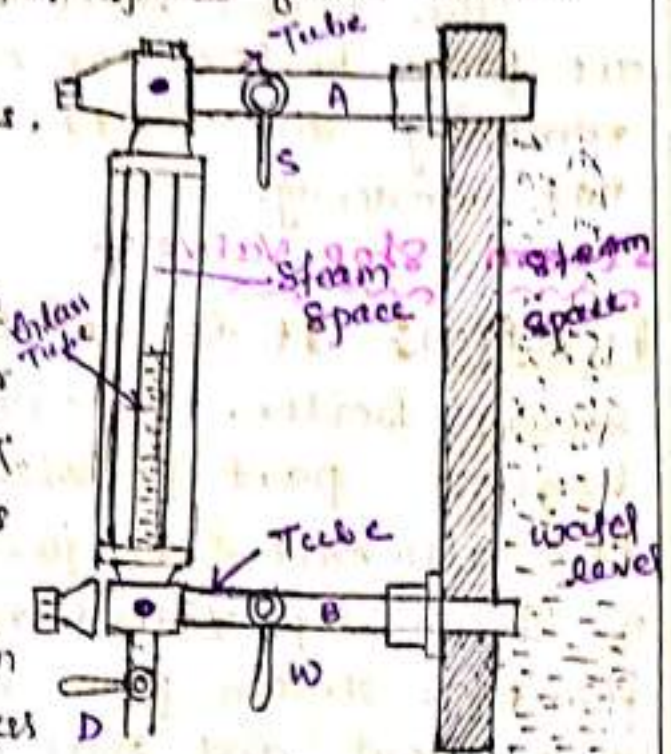

The rectangular passage at the ends of the glass tube certain two balls. In case the glass tube is broken, the balls are carried along its passage to the ends of glass tube and flow of water and steam out of the boiler is prevented.

The water level indicator can be taken out from boiler for cleaning purpose by removing the bolts when the boiler is not working.

### Steam Stop Valve :-

Function :- It is the largest valve on the steam boiler. Generally it is fitted to the highest part of boiler shell and steam pipe. It is also called as junction valve. The function of steam stop valve regulates and controls the flow of steam from boiler to engine as per requirement and shut-off the steam flow when not required.

### Construction & Working Principle :-

It consists of a valve 'V' which is held in a gunmetal valve seat (S) contained in a valve chest (VC). The valve is carried at the end of a vertical spindle (R) which is provided with a hand wheel H at its top. The vertical spindle whose upper part is threaded, passes through a Nut (N) fitted in the part called yoke. The valve is operated by the hand wheel H. When the valve is lifted

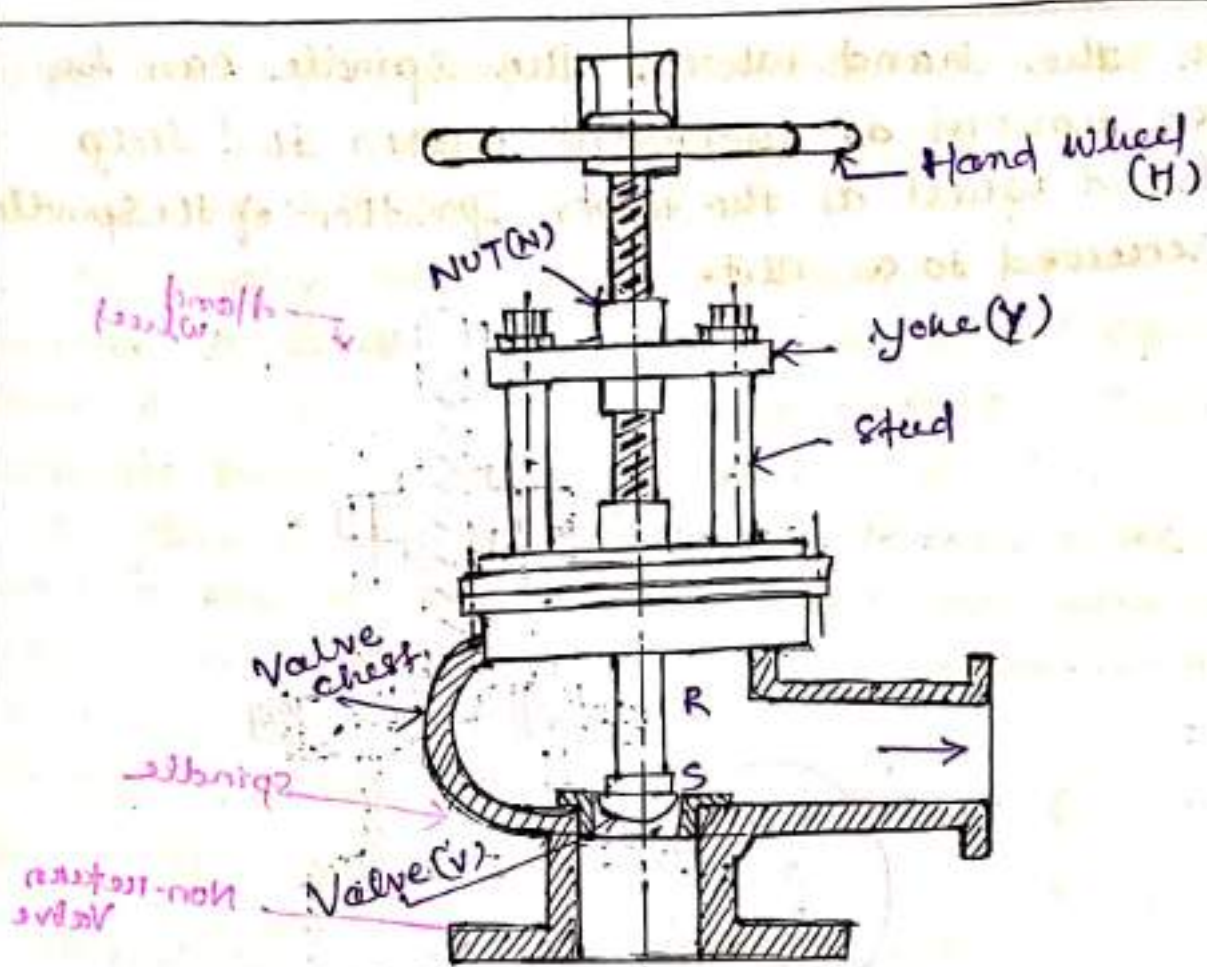

up from its seat, steam flows from the boiler through the steam pipe and when it is placed on its seat flow of steam from the boiler can no longer take place.

Feed check valve:-

Function:- The function of the feed check valve is to allow the supply of water to the boiler at a higher pressure than boiler pressure continuously and to prevent back flow of water from the boiler when the pump pressure is less than boiler pressure or when pump fails.

Construction & Working Principle:- Generally

it is fitted to the shell slightly below the normal water level of the boiler. The left of the non-return valve is regulated by the end position of the spindle which is attached

With the hand wheel. The spindle can be moved upward or downward. With the help of hand wheel as the upper position of the spindle is screwed to a nut.

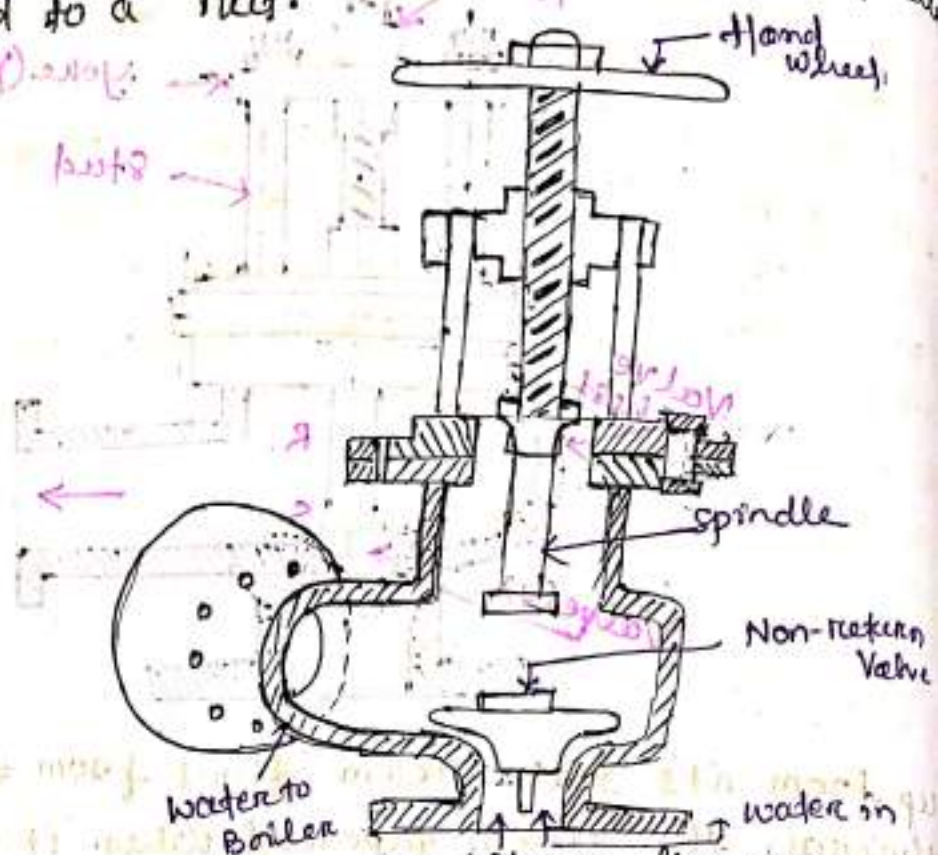

At normal working condition, the non-return valve is lifted due to the pressure of water from the pump and the water is fed to the boiler. But when the pump pressure falls below boiler pressure or if the pump stops, non return valve is closed automatically due to the pressure of the water from the boiler and prevents the escape of water from the boiler.

Pressure Gauge: Pressure gauge is an apparatus whose function is to indicate the pressure of a fluid (i.e. gas or liquid). When pressure gauge is used in boilers, its function is to indicate the pressure of the steam within

the boiler. Generally it is fixed in front of the steam boiler.

### Construction and working Principle:-

Generally the pressure gauges used are of Bourdon type. It consists of an elliptical elastic tube ABC bent into an arc of a circle. This bent up tube is called Bourdon's tube. One end of the tube is fixed and connected to the steam space of the boiler and other end is connected to a sector wheel through a link. The steam under pressure, flows into the tube. As a result

of the increased pressure the Bourdon's tube tends to straighten itself, since the tube is enclosed in a circular curve, therefore it tends to become circular instead of straight. With the help of a simple pinion and sector arrangement the elastic deformation of the Bourdon's tube rotates the pointer. This pointer moves over a calibrated scale, which directly gives the gauge pressure.

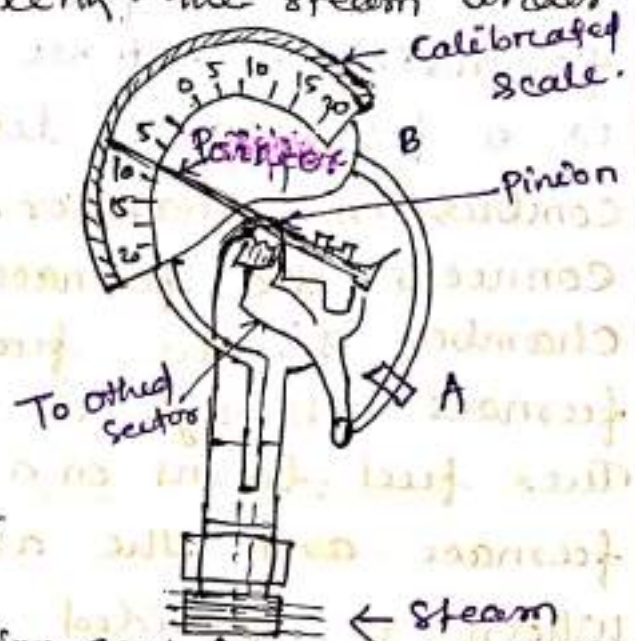

### :- COCHRAN BOILERS :-

Cochran boiler is a fire tube type, vertical multitubular, internally fired natural circulation & portable type of boiler. It is approximately 2.75m in diameter and 5.5m in height. It has got a number of horizontal fire tubes. The working pressure range & evaporative capacity are approximately 20 kg/cm<sup>2</sup> & 3500 kg/hr respectively.

This boiler consists of an external cylindrical shell & a fire box. It consists of a number of horizontal tubes, called flue tubes which are fitted to vertical cylindrical shell. The shell & fire box both are hemispherical. The hemispherical crown of the boiler shell gives max<sup>m</sup> space and strength to withstand the pressure of steam inside the boiler. The hemispherical crown of the fire box is also advantageous for resisting intense heat. In the figure (B) is a fire brick lined chamber, called combustion chamber. There is a short pipe (E) connects the furnace 'A' with the combustion chamber (B). The fuel is introduced into the furnace through a door (F), called fire door. The fuel burns on a grate within the furnace and the ashes fall into the ash pit which is provided beneath the grate.

The coal on burning, produces hot flue gases and these hot products of combustion chamber (B) from the fire box enter through the short pipe (E). From the combustion chamber (B), the flue gases pass through the horizontal flue tubes to a box (C), called smoke box. From the smoke box (C), the flue gases escape into the atmosphere through the chimney (D). The path of the flue gases has been shown by arrows in the figure.

Thus due to continuous flow of flue gases through the flue tubes, the water which surrounds them, becomes more and more heated and ultimately it reaches its boiling point, temperature & steam begins to be produced. The steam thus generated collects in the steam space within the boiler in the figure.

P is the pressure gauge, W is the water level indicator, S is the safety valve, T is the steam stop valve, M is the man hole and V is the blow off cock, F for fusible plug has been shown in the figure.

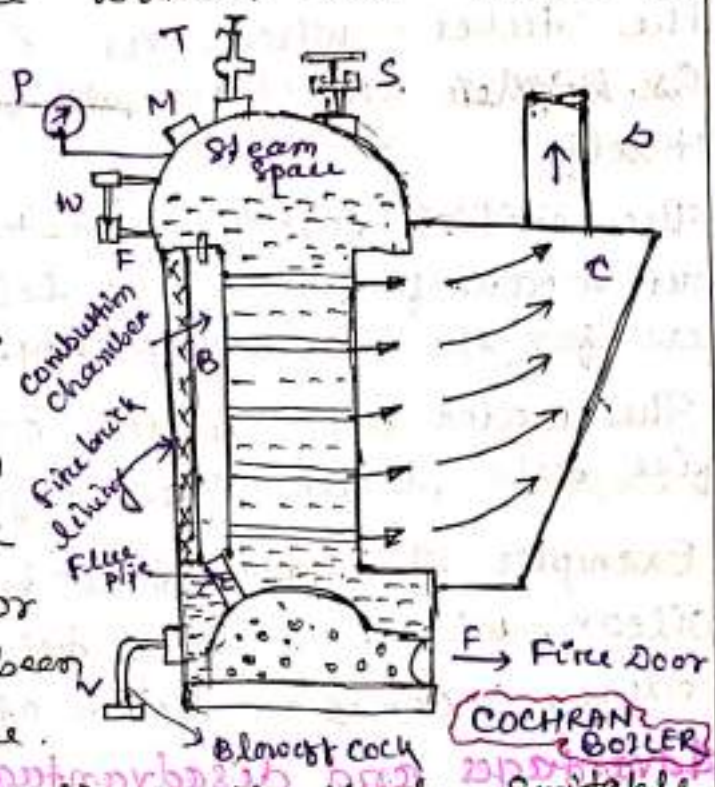

Cochran boiler is particularly suitable for its portability, the small amount of floor space required for its installation and the rapidity with which it can be put to work.

### Difference Between water tube and fire tube Boiler:-

- In the water tube boiler, the hot gases pass around a large number of tubes through which the water circulates, whereas in a fire tube boiler, the hot gases pass through the flue tubes.



- ② In the water tube boilers, the furnace will be situated outside the boiler shell where as in a fire tube boiler, the furnace will be within the boiler shell.
- ③ In water tube boilers, water will be continuous circulation between the down & the tubes where as in a fire tube boiler the water circulates ~~will be~~ within the drum itself.
- ④ The initial cost of water-tube boiler is higher but in case of fire tube boiler initial cost is less for the same capacity.
- ⑤ The water tube boiler occupies less space than fire tube boiler for a given power.
- ⑥ Examples of water tube boilers are Babcock & Wilcox, where as fire tube boilers are Cochran boiler, locomotive boiler etc.

### Advantages and disadvantages of water tube Boiler over fire tube Boilers:-

#### Advantages:-

- (i) In case of water tube boilers, the ratio of water content to steam capacity is comparatively less than the fire tube boiler hence water tube boilers quickly generate steam at the required pressure, than the fire tube boiler.
- (ii) The water tube boilers, do not contain any tubes inside the drum. Hence the diameter of the drum of the water tube boiler will be

less than that of the fire tube boiler. Consequently the water tube boilers can withstand high pressure for the same wall thickness & stress. Therefore water tube boilers can develop higher pressure than the fire tube boilers.

- (iii) The heat transfer in the water tube boiler is more effective than the fire tube boiler since the hot gases flow at right angles to the water tubes.
- (iv) For a given power, water tube boiler occupies less space than that of the fire tube boiler.
- (v) All parts of the water tube boilers are easily accessible when compared to the fire tube boilers for cleaning, repairing and inspection.
- (vi) Water tube boilers can be easily dismantled conveniently transported and erected quickly at the site than a fire tube boiler.

#### Dis-advantages :-

- (1) Water tube boiler requires pure feed water, because impure feed water forms scale in the water tube, consequently there will be overheating and bursting of the water tubes.
- (2) Water tube boilers are not suited for mobile purpose.
- (3) The initial cost of the water tube boiler is more than that of the fire tube boiler allows to escape.

Blow-off cock :- The principal functions of a blow off cock are.

- (i) To empty the boiler whenever required.
- (ii) To discharge the mud, scale or sediments which are accumulated at the bottom of the boiler.