

LABORATORY MANUAL

ELECTRICAL MACHINE LAB - I

4TH SEMESTER
ELECTRICAL ENGINEERING

GOVT. POLYTECHNIC
MALKANGIRI

CONTENTS

Sl. No.	List of experiments
1	Identification of different terminals of a dc machine by lamp method & multi-meter method and to measure insulation resistance by megger.
2	Dimensional and material study of various parts of a dc machine.
3	Study of three-point starter, connect and run a dc shunt motor and measure the no load current.
4	Study of four-point starter, connect and run a dc compound motor and measure no load current.
5	Control the speed of a dc shunt motor by field control method, control the speed of a dc compound motor by armature voltage control method.
6	Identification of terminals of a single-phase transformer by performing polarity test.
7	Open circuit test and Short circuit test of a single-phase transformer.
8	Determine voltage regulation of transformer by direct loading.
9	The parallel operation of a single-phase transformer
10	Determine the efficiency of a dc machine by brake test method.

EXPERIMENTT- 1

AIM OF THE EXPERIMENT: Identification of different terminals of a DC machine by test Lamp method & multi-meter method and to measure insulation resistance by megger.

EQUIPMENTS REQUIRED:

Sl. No.	Name of equipment	Specification	Quantity
01	DC compound wound motor	220V, 3KW, 1500rpm, 13.5A	1no
02	Megger	50M Ω , (0-35) Ω	1no
03	Digital multimeter	100Amp	1no
04	Series test lamp	100 watt, 220V	1set

THEORY:

A dc motor mainly consists of two windings as (a) Armature winding (b) field winding. In case of series dc motor field contain series winding only while shunt motor field contain shunt field winding but in case of compound wound dc motor field winding contain both series and shunt winding since each winding has two terminals in case of compound wound motor. There are three winding 6 terminals which located at top and attached with it.

To identify the terminals and measure the insulating resistance of the winding. Let consider a dc compound wound motor which has three winding and six terminals are kept in a terminal box and attached with a yoke or frame of the motor. The equivalent circuit diagrams of this motor with its terminals are given in the figure for observation point of view.

DIAGRAM:

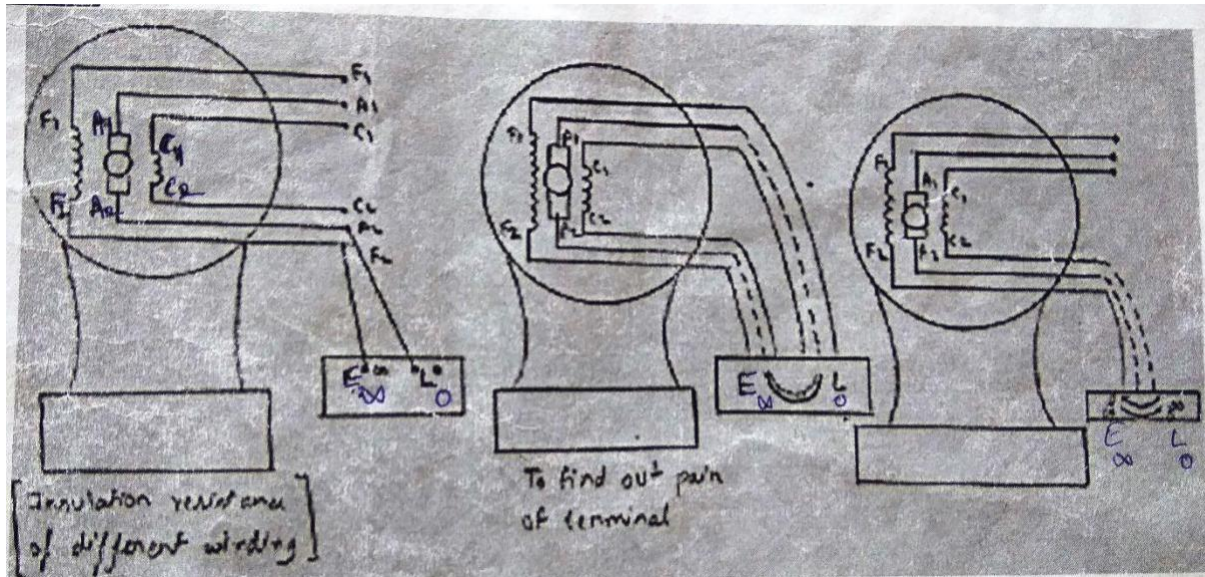

INSULATION RESISTANCE TEST (BETWEEN WINDING AND BODY):

The aim of this test is that there should be no wire touching of the body. The “E” terminal of megger is connected to the body and 1 terminal should touch the terminal of the generator or motor one by one and rotate the handle at 160 rpm. Note the reading.

INSULATION RESISTANCE TEST (BETWEEN DIFFERENT TERMINALS):

The aim of this test is to check that the winding which should be insulated from each other are insulated or not. For this test touch the “E” terminal of the megger with shunt field winding F1&F2 terminal and “1” terminal of the megger to armature terminal A1 & A2 and rotate the handle of the megger. If the megger shows “infinite”, it means that there is high resistance between two windings. If the megger shows zero it means that the both winding are short circuited with each other. Then test between A1 or A2, C1 or C2, F1 or F2.

PROCEDURE:

- Open all the terminal connection of the dc compound motor
- Give supply to series test lamp
- Connect the series test lamp to the terminals of dc compound motor in hit and trial method
- when the bulb glows, it shows that the terminals are of same winding
- now connect the megger to the dc motor terminals to check the terminals and the insulation resistance of the windings
- if the pointer of the megger deflects towards ‘0’ it is terminals of same winding and if the pointer of megger remains in infinity position then it is not of same winding
- now connect the multimeter to check the resistance of different windings and specify them

OBSERVATION TABLE:

Sl no	Terminals connected to megger	Terminals connected to resistance	Pair of terminal (Y/N)	Remarks
1	1-2	Inf	N	
2	1-3	0	Y	
3	1-4	Inf	N	
4	1-5	Inf	N	
5	2-4	Inf	N	
6	2-5	0	Y	
7	2-6	Inf	N	
8	4-5	Inf	N	
9	4-6	0	Y	

TERMINAL IDENTIFICATION:

Assumed pair of terminals	Terminal of exact pair	Value if insulating resistance	Types of winding
1-3	A1-A2	0.87 ohm	Armature
4-6	F1-F2	0.88kohm	Shunt winding
2-5	C1-C2	3.4 ohm	Field winding

CONCLUSION:

DISCUSSION QUESTIONS

1. Describe the working of megger?

EXPERIMENT- 2

AIM OF THE EXPERIMENT:

Dimensional and material study of various parts of a DC machine.

EQUIPMENTS REQUIRED: DC machine

THEORY:

An electrical machine is a mechanical device which converts mechanical energy into electrical energy. The energy conversion based on the principle of production of dynamically induced emf. A production machine consists of the following essential parts.

PARTS OF A DC MACHINE

- i. Pole core & pole shoe
- ii. Magnetic yoke or frame
- iii. Pole coils or field coils
- iv. Armature core
- v. Armature winding or conductor
- vi. Commutator
- vii. Brushes

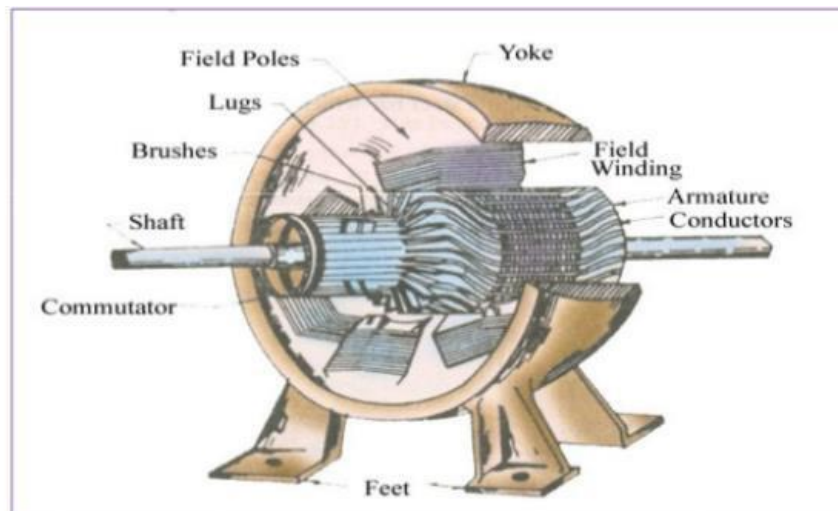

MAGNETIC FRAME OR YOKE

The outer frame of a dc machine is known as yoke. It acts as a protective cover for the DC machine as well as it provides machine supports for the poles. It also carries magnetic field produced by the poles. Yokes are made of cast iron, but for large machine usually cast steel or rolled steel. The modern process of forming yoke is consisting of rolling a steel slab.

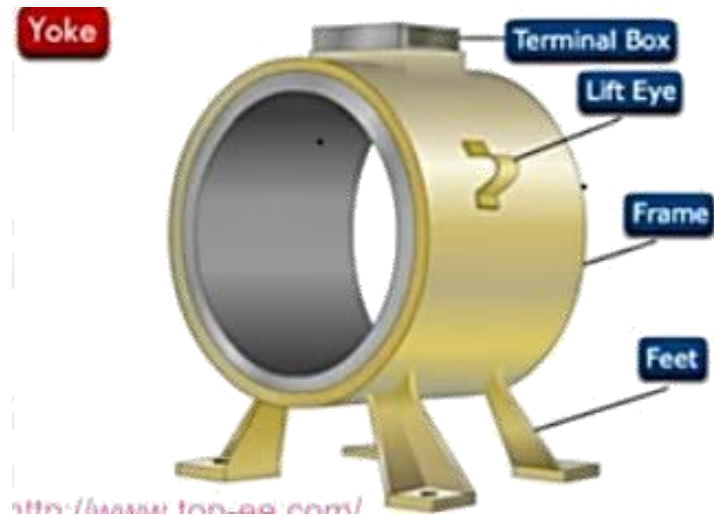

POLE CORE OR POLE SHOE

For the purpose in a machine either permanent poles or electro magnet poles are attached or welded with yoke. The field magnet consists of pole core and pole shoe. Pole shoe serves for two purpose

- i. They spread out the flux in the air gap
- ii. They support the field coil or field winding.

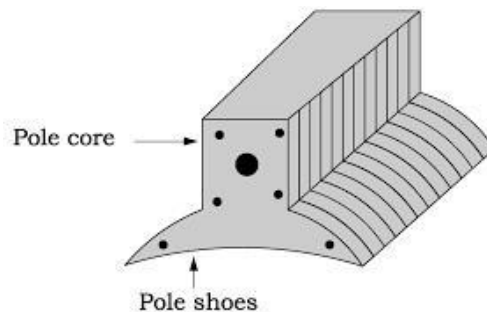
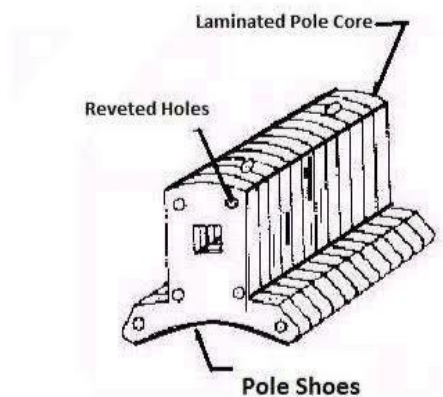

POLE COILS OR FIELD COILS

The pole coils consist of copper wire or strips. When current is passed through these coils, the electro magnets produce the necessary flux that cut by revolving armature conductor.

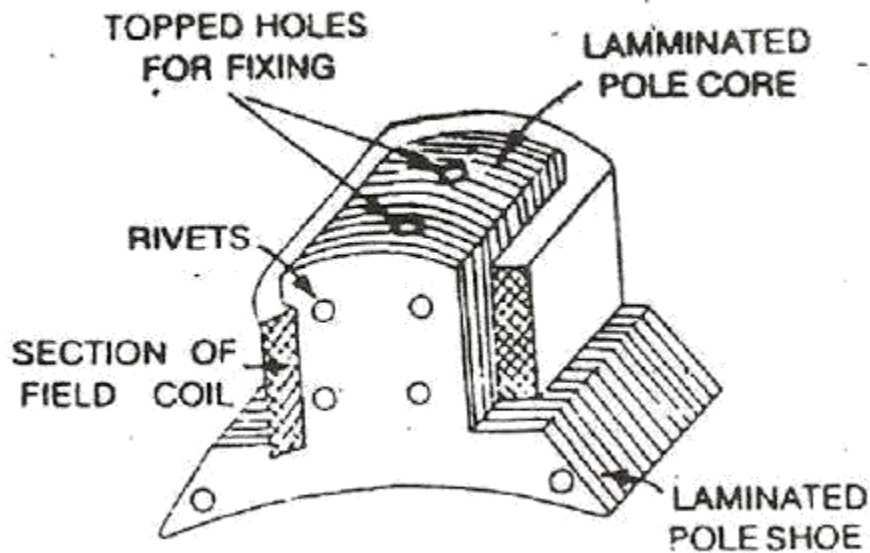

ARMATURE CORE

It causes the armature conductor to rotate. The important function of the armature core is to provide a path of very low reluctance to the flux through the armature. It is cylindrical is made of circular sheet steel disc on lamination.



ARMATURE WINDING OR CONDUCTOR

Within the slot of armature core copper windings are provide and known as armature winding. It consist of large number of insulated coils. Each coil having one or more number of turns. The coils are usually former wound. These are placed in a slot. Depending upon the type of winding required. These are basically two types of winding.

- i. Lap winding
- ii. Wave winding

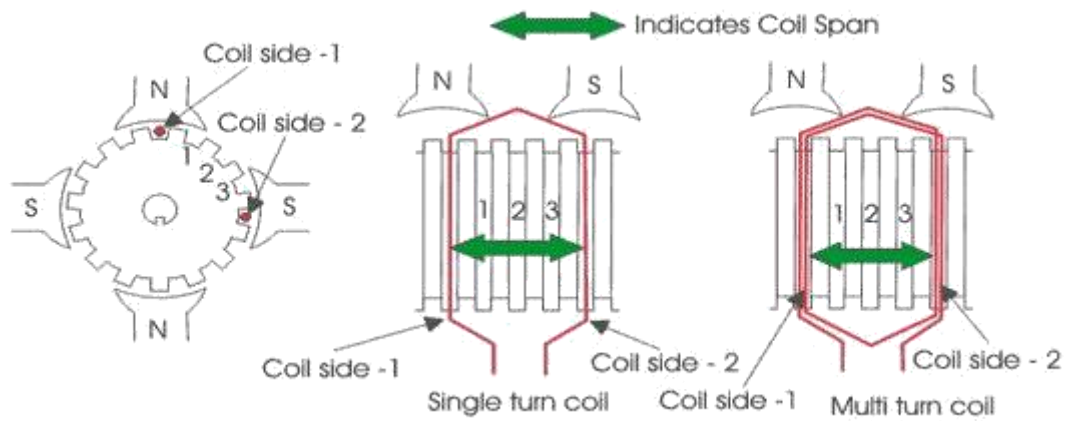

COMMUTATOR

It is of cylindrical structure. It is built of wedge shaped segment of high conductivity hard drawn copper to reduce its wear and tear segments are insulated from each other by 0.8mm thick mica sheet. The segments are assembly in such a way that result in circular shape. The commutator in DC machine is used to convert AC to DC.

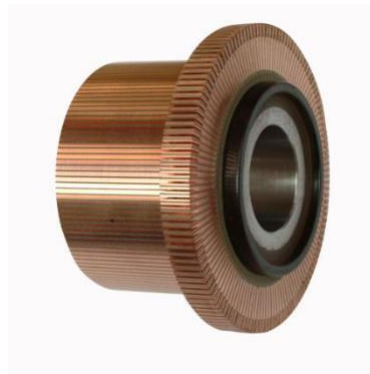

BRUSHES

Brushes are based in box type brush holder attach to the stator yoke. A small spring keeps the brushes passed on to the commutator surface. Brushes are made of carbon for small DC machine, electro graphite for all DC machine and copper graphite for low voltage high current DC machine.

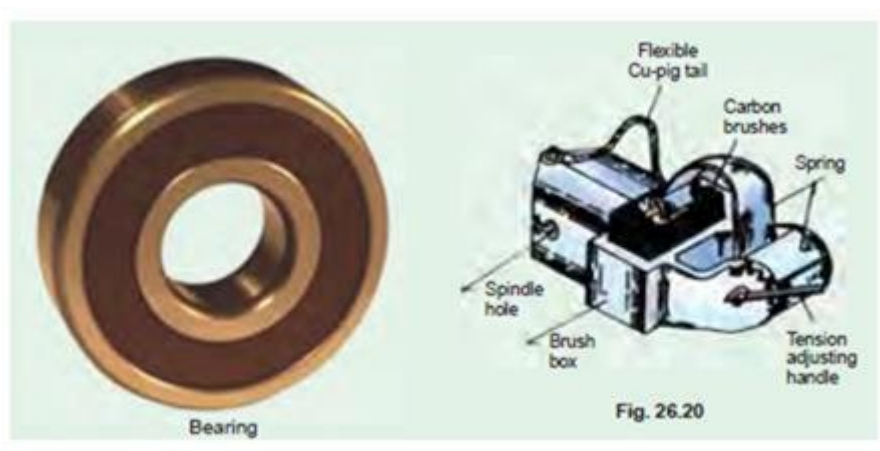

CONCLUSION

DISCUSSION QUESTION

1. The yoke is made of which material and why?.
2. The commutator is made of which material and why?
3. What is the function of brushes?
4. Why the field pole shoes are curved in nature?
5. State Fleming's Right Hand rule?

EXPERIMENT NO- 3

AIM OF THE EXPERIMENT:

Study of three point starter, connect and run a DC shunt motor and measure the no load current.

EQUIPMENT REQUIRED:

Sl no.	Apparatus required	Specifications	Quantity
1	DC shunt motor	220V, 17.5A, 1500rpm, 3KW	1no
2	3 point starter	22KW, 230V, 12Amp	1no
3	DC ammeter	0-20A	1no
4	Combinational pliers	150mm	1no
5	Screw driver	300mm	1no
6	Spanner		1no
7	Tester	0-500V	1no
8	Connecting wires		As per required

THEORY:

The primary function of a starter is to limiting the starting current. At the starting time of the motor the back emf is zero. So at starting time the current is dangerously high. Hence a motor can be damaged. So starter is used to minimize the starting current. The face plate box type starter used for starting shunt and compound motor of ordinary, industrial capacity are of two types, known as 3 point and 4 point starter respectively.

3 POINT STARTER

There are three terminals available in this starter and it is named as 3-point starter, which is marked as L, Z, A. The three-point starter terminals are line, field and armature. The terminal L is connected to the positive of main supply (+), the other line (-) is connected to one armature terminal and field terminal which are tied together. Point A is further connected to starting arm through over current release coil or over load release coil (M) to start the motor. The main switch is closed then the starting arm is slowly moved to the right. As soon as the arm make contact with stud no 1, the field circuit is directly connected across the line at the same time full starting resistance is placed in series with the armature. The starting current drawn by the

$$I_a = V / (R_a + R_s)$$

Where R_a = armature resistance

R_s = starting resistance

As the arm is further move the starting resistance is gradually, cut out till when the arm reaches the running position the resistance is all cut-outs.

The arm moves over the various studs again a starting force which tends to restore an off position.

There is a soft iron piece attached to the arm which in the full on running position is attracted and held by the shunt current. It is also known as hold on coil or low voltage release coil.

The arm is moved from stud no 1 to the last stud the current has to travel back through the point of starting resistance that has been cut out the armature circuit. This result slide decrease of shunt current but as the value of starting resistance is very small as compared to shunt field resistance; this slide

decrease in I_{sh} is negligible. This effect can be remedied by using a brush field circuit which is completed through the starting resistance. The action of two protective devices of 3 point starter

FUNCTION OF NO-LOAD RELEASE COIL

- i. The function of hold on coil is to hold on the arm in the full running position then motor is in normal operation. In cases of failure or disconnection of the supply to the off position.
- ii. This prevents the stationary armature from the input across the line again when the supply is restoring after temporary shutdown.
- iii. Advantage of connecting the hold on coil in series with the shunt field is that when the field circuit becomes open, the starting arm immediately springs back to the off position the motor from running away.

FUNCTION OF OVER LOAD RELEASE COIL

- i. Overload release coil consists of an electromagnet connected in the supply line. If the motor becomes overloaded beyond a certain predetermined value then the iron piece (D) is lifted and short circuits the electromagnet. Hence, the arm is released and returns to off position.
- ii. The 3 point starter can't be used in variable speed motor to overcome this drawback 4 point starter is used in dc motor.

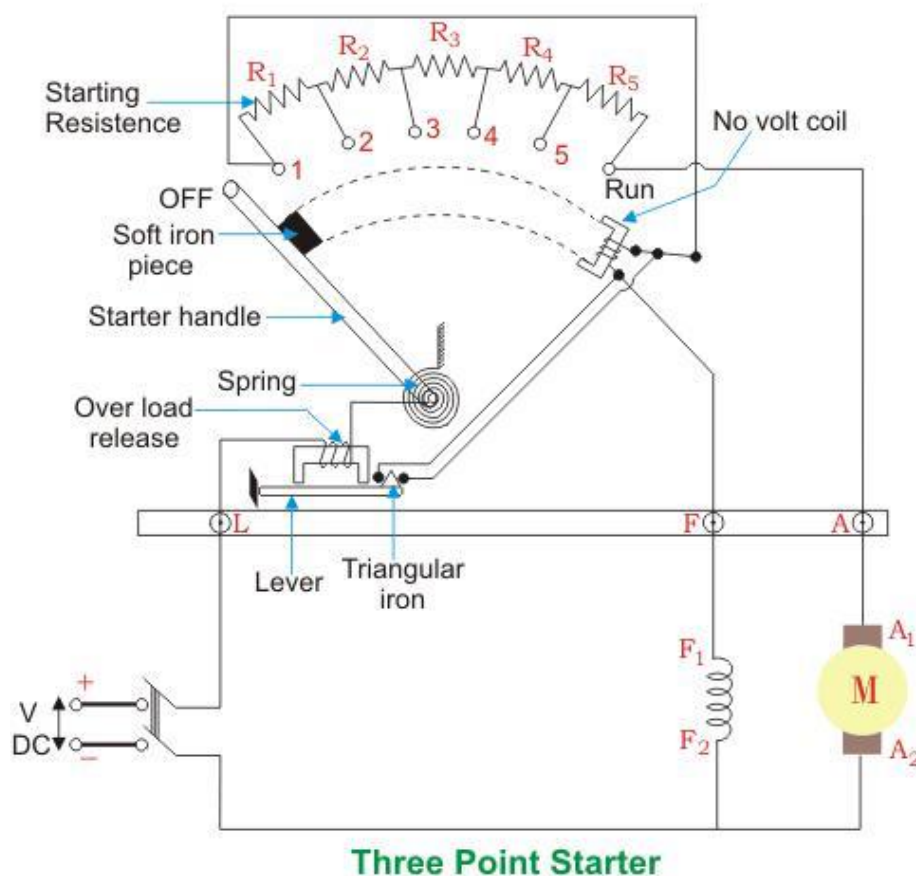

OBSERVATION

No load current= _____ amp , load current= _____ amp

CONCLUSION

DISCUSSION QUESTION

1. Write the function of no volt coil?
2. Where the function of over load release coil?
3. Where is three point starter used?
4. What is the material used for making stud used in 3 point starter?

EXPERIMENT NO- 4

AIM OF THE EXPERIMENT:

Study of four point starter, connect and run a DC shunt motor and measure the no load current.

EQUIPMENT REQUIRED:

Sl no.	Apparatus required	Specifications	Quantity
1	DC shunt motor	220V, 17.5A, 1500rpm, 3KW	1no
2	4 point starter		1no
3	DC ammeter	0-20A	1no
4	Combinational pliers	150mm	1no
5	Screw driver	300mm	1no
6	Spanner		1no
7	Tester	0-500V	1no
8	Connecting wires		As per required

THEORY:

The primary function of a starter is to limiting the starting current. At the starting time of the motor the back emf is zero. So at starting time the current is dangerously high. Hence a motor can be damaged. So starter is used to minimize the starting current. The face plate box type starter used for starting shunt and compound motor of ordinary, industrial capacity are of two types, known as 3 point and 4 point starter respectively.

4 POINT STARTER

- i. Such a type of starter is connected to long shunt compound motor for desirable control of speed of motor. 4 point starter has four terminals namely line terminal 'L', armature terminal 'A', and resistance terminal 'R'.
- ii. In 4 point starter hold on coil 1 has been taken out of the shunt field circuit and has been connected to directly across the line through a protect resistance R.
- iii. When the arm touches the stud no 1 then the line current divided into 3 parts. One part passes through starting resistance R_s series field ad motor armature. Second part passes through the shunt field and its field rheostat R_b . Third part passes through the hold on coil and current protecting resistance R from the above arrangement any change in the shunt field circuit doesn't at all affect the current passing through the hold on coil because the two circuits are independent to each other.
- iv. It means that the electromagnetic pull exerted by the hold on coil will always be sufficient and prevent the spring from restoring the starting arm to off position no matter how the field rheostat or regulator is adjusted.

FUNCTION OF NO LOAD RELEASE COIL

- i. The function of hold on coil is to hold on the arm in the full running position then motor is in normal operation. In cases of failure or disconnection of the supply to the off position.
- ii. This prevents the stationary armature from the input across the line again when the supply is restoring after temporary shutdown.

- iii. Advantage of connecting the hold on coil in series with the shunt field is that when the field circuit becomes open, the starting arm immediately spring back to the off position the motor from running away.

FUNCTION OF OVER LOAD RELEASE COIL

Overload release coil consist of an electromagnet connected in the supply line. If the motor became over loaded beyond a certain predetermined value than the iron piece (D) is lifted and short circuit the electromagnet. Hence, the arm is released and returns to off position.

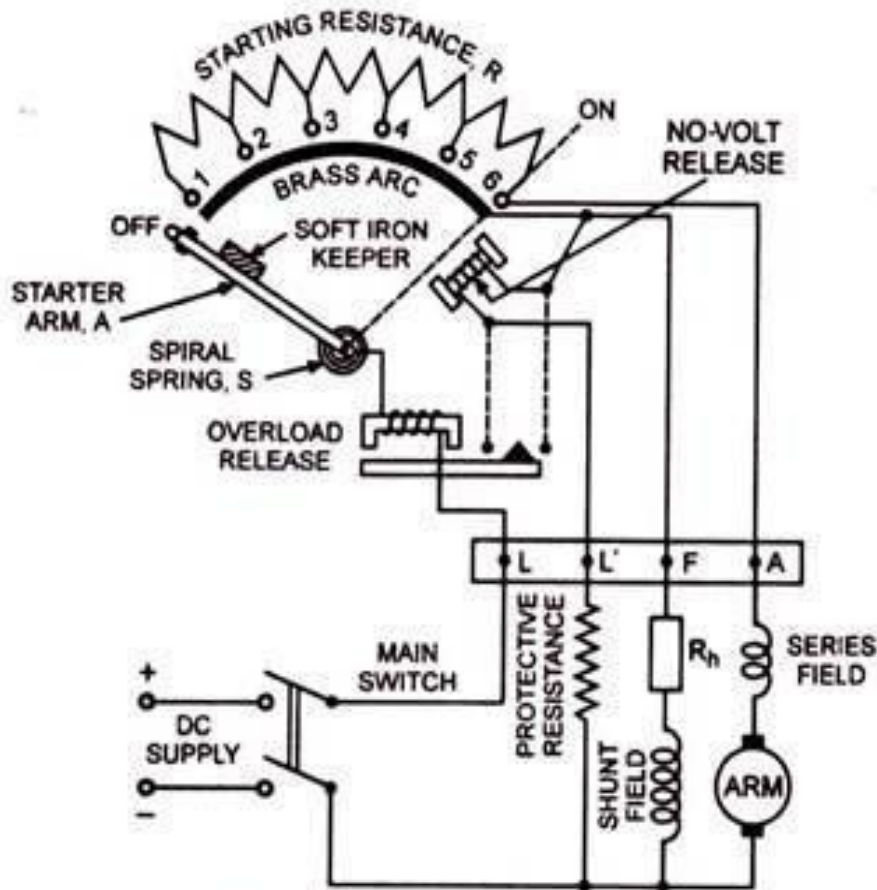

Fig. 1.60. *Four-Point Starter*

OBSERVATION:

No load current = _____ amp Load current= _____ amp

CONCLUSION

DISCUSSION QUESTION

1. Write the function of no volt coil?
2. Where the function of over load release coil?
3. Where is four point starter used?
4. What is the difference between 3 point and 4 point starter?

EXPERIMENT- 5(A)

AIM OF THE EXPERIMENT:

Control the speed of a dc shunt motor by field control method.

EQUIPMENTS REQUIRED:

Sl no	Equipment name	Specifications	Quantity
1	DC shunt motor	229V, 13.5A, 1500rpm, 3KW	1no
2	Field rheostat	0-250Ω	1no
3	Tachometer	Digital type	1no
4	Connecting wire		As per required

THEORY:

SPEED CONTROL OF DC SHUNT MOTOR

VARIATION OF FLUX OR FLUX CONTRL METHOD

We know that $N \propto 1/\Phi$. By decreasing the flux, the speed can be increased and vice versa. Hence, the name flux or field control method. The flux of a dc motor can be changed by changing shunt current I_{sh} with help of a shunt field rheostat. Since shunt current I_{sh} is relatively small, shunt field rheostat has to carry only a small current, which means I^2R loss is small, so that rheostat is small in size. This method is, therefore, very efficient in non-inter-polar machine, the speed can be increased by this method in the ratio 2:1. Any further weakening of flux Φ adversely affects the commutation and hence puts a limit to the maximum speed obtainable with this method. In machine fitted with interpoles, a ratio of maximum to minimum speed 6:1 is fairly common.

DIAGRAM:

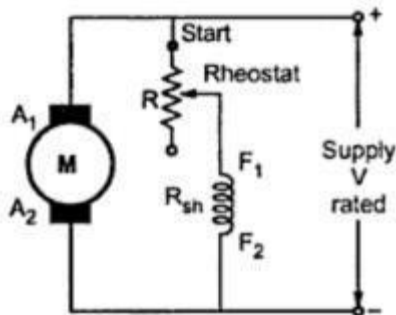

PROCEDURE:

- Make the connections as per the given circuit diagram.
- Connect the external resistance in series with the field circuit.
- Initially keep the rheostat in minimum resistance position (zero).
- Now switch on the supply.
- Note down the motor speed at minimum rheostat position.
- Then change the rheostat position gradually to maximum resistance value.
- Note down the motor speed at maximum resistance value.
- Then switch off the supply.

OBSERVATION:

At minimum resistance: speed= _____ rpm

At maximum resistance: speed= _____ rpm

CONCLUSION:

DISCUSSION QUESTION:

1. What are the different methods to control speed of dc motor?
2. Explain the method of speed control by field control method?
3. Explain the characteristics (electrical) of dc shunt motor?
4. What is critical resistance?

EXPERIMENT- 5(B)

AIM OF THE EXPERIMENT:

Control the speed of a dc compound motor by armature voltage control method.

EQUIPMENTS REQUIRED

Sl no	Name of equipment	Specifications	Quantity
1	DC compound motor		1no
2	Rheostat		1no
3	Tachometer	<u>Digital type</u>	1no
4	Connecting wires		As per reqd

THEORY:

ARMATURE OR VOLTAGE CONTROL METHOD

This method is used when speed below the no-load speed are required. As the supply voltage is normally constant, the voltage across the armature is varied by inserting a variable rheostat or resistance (called controller resistance) in series with the armature circuit as shown in fig. As controller resistance is increased, pd across armature is decreased, thereby decreasing the armature speed. For a load constant torque, speed is approximately proportional to the pd across the armature. From the speed vs armature current characteristic, it is seen that greater the resistance in the armature circuit, greater is the fall in speed.

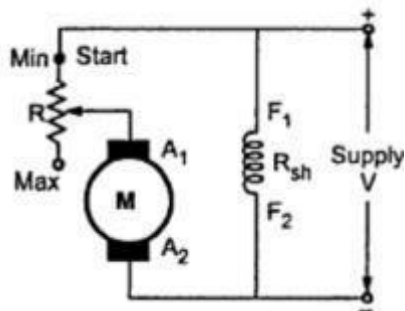

Let I_{a1} = armature current in 1st case

I_{a2} = armature current in 2nd case

(if $I_{a1} = I_{a2}$ then load is of constant torque)

N_1, N_2 = corresponding speed, V = supply voltage

Then $N_1 \propto V - I_{a1}R_a \propto E_{b1}$

Let some controller resistance of value R be added to the armature circuit resistance so that its value become $(R + R_a) = R_r$

Then $N_2 \propto V - I_{a2}R_a \propto E_{b2}$

$\therefore N_2/N_1 = E_{b2}/E_{b1}$

(In fact, it is a simplified form of relation given because here $\Phi_1 = \Phi_2$)

Considering no load speed, we have $N/N_0 = V - I_a R_t / (V - I_{a0} R_a)$

Neglecting $I_{a0} R_a$ w.r.t V , we get $N = N_0(1 - I_a R_t / V)$

It is seen that for a given resistance R_t the speed is a linear function of armature current I_a .

The load current for which the speed would be zero is found by putting $N=0$ in the above relation

$$\therefore 0 = N_0(1 - I_a R_t / V) \text{ or } I_a = V / R_t$$

This is the maximum current and is known as stalling current.

As will be shown in the diagram this method is very wasteful, expensive and unsuitable for rapidly changing load because for a given value of R_t , speed will change with load. A more stable operation can be obtained by using a diverter across the armature in addition to armature control resistance. Now the changes in armature current (due to changes in the load torque) will not be so effective in changing the pd across the armature (and hence the armature speed).

PROCEDURE:

- Make the connection as per the circuit diagram
- Connect the rheostat in series with the armature
- Initially keep the rheostat in minimum resistance position (zero)
- Switch on the supply
- Note down the speed of motor at minimum rheostat position
- Now increase the rheostat value gradually to its maximum level
- Note down the speed of motor at maximum rheostat position
- Switch off the supply

OBSERVATION:

At minimum rheostat value: speed = _____ rpm

At maximum rheostat value: speed = _____ rpm

CONCLUSION:

DISCUSSION QUESTION:

1. Write the methods to control the speed of a DC shunt motor?
2. Explain the armature voltage control method?
3. What is back emf?
4. What is Lenz's law?

EXPERIMENT- 6(A)

AIM OF THE EXPERIMENT:

Identification of terminals of a single phase transformer by performing polarity test.

EQUIPMENTS REQUIRED

Sl no.	Name	Specifications	Quantity
1	Single phase transformer	1KVA,0-115A-199- 230V, 50Hz	1no
2	Variac	0-270V	1no
3	Voltmeter	0-300-600V AC/DC	2no
4	Single core copper wire		As per reqd
5	Knife		1no

THEORY:

Transformer is a static device which performs the function of power transformation from one circuit to another circuit at the same frequency by mutual inductance. The first coil in which electrical energy is fed from the ac supply main is called the primary winding. The no. of turns in the primary coil may or may not be equal to the no. of turns in the secondary coil on the primary winding and secondary winding of the transformer respectively. One terminal is +ve wrt to other terminal at one instant. The relative polarities of the primary and the secondary terminal at any instant must be operated in parallel or be used in poly phase circuit.

DIAGRAM:

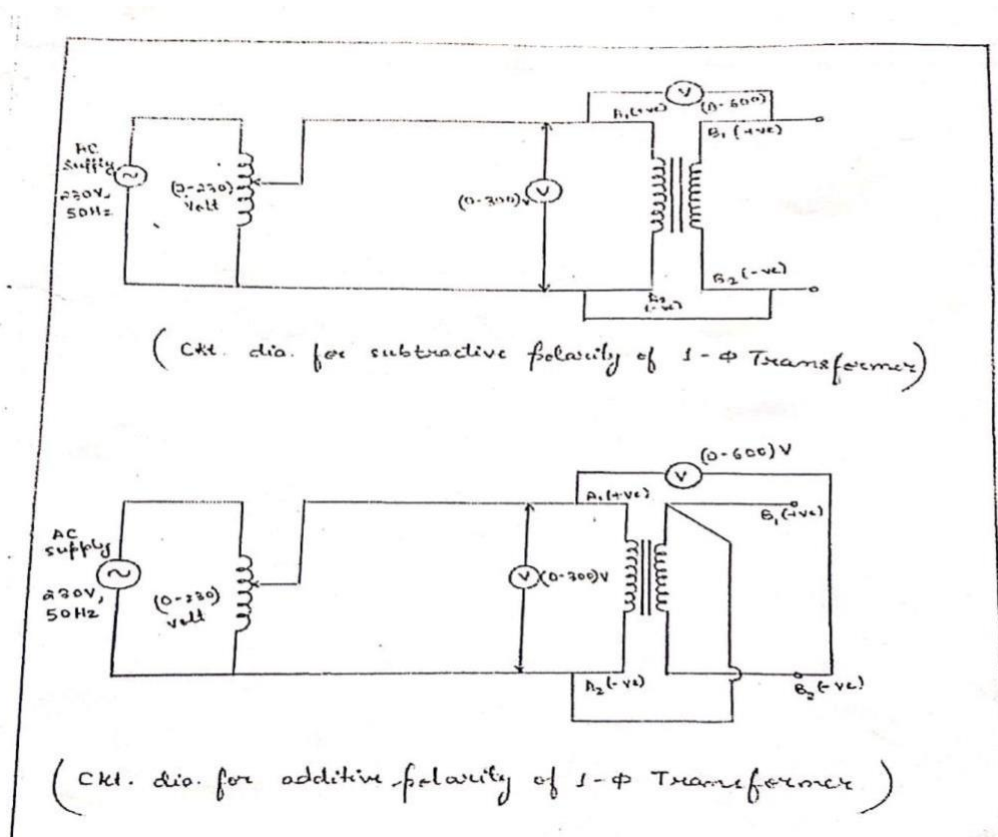

PROCEDURE:

- i. Connect the primary and secondary coil as shown in fig. Arbitrarily fix the primary winding terminal as A1 & A2 and the secondary terminal as B1 and B2.
- ii. Join A1 & B1 through voltmeter (V) of (0-600)V.
- iii. Connect A2 & B2 in phase and voltage of 230V to the primary.
- iv. If the voltmeter reading is more than presented voltage of 230V, it is an additive polarity marked B1 as -ve & B2 as +ve.
- v. If the voltage read by the voltmeter is less than 230V, it is subtractive polarity and the terminal B1 is to be marked +ve and B2 is -ve for assume polarity of A1 is +ve and A2 is -ve.

OBSERVATION:**FOR ADDITIVE**

Sl no	Primary	Secondary	Remark
1	100V	200V	Additive
2	150V	300V	Additive
3	220V	450V	Additive

FOR SUBTRACTIVE

Sl no	Primary	Secondary	Remark
1	100V	0V	Subtractive
2	150V	0V	Subtractive
3	220V	0V	Subtractive

CONCLUSION:**DISCUSSION QUESTION:**

- i. What is transformer?
- ii. What are the different types of transformer based on construction, explain the diagram?
- iii. What is transformer ratio?
- iv. What is expression for hysteresis loss?
- v. What is eddy current loss?

EXPERIMENT- 6(B)

AIM OF THE EXPERIMENT:

Determination of voltage transformation ratio of single phase transformer.

APPARATUS REQUIRED:

SL. NO.	NAME	SPECIFICATION	QUANTITY
1	Single phase transformer	1 KVA	1
2	1 Phase Variac	0-270 V	1
3	Voltmeter	0-300-600 V	2
4	Connecting wire	--	As per required
5	Combination Plier	--	1

THEORY:

Transformer is a static piece of apparatus by means of which electric power in one circuit is transformed into electric power of the same frequency in another circuit.

It can rise or lower the voltage in a circuit but with a corresponding decrease or increase in current.

The physical basis of a transformer is a mutual induction between two circuit linked by a common magnetic flux

It consists of two inductive coil which are electrically separated but magnetically linked through a path of low reluctance.

The coil possess high mutual inductance if one coil is connected to a source of alternating voltage and alternating flux in the laminated core, path of which is linked with the other coil in which is produce mutually induced EMF.

If the second coil is closed a current flows in it and no electric energy is lost offered from the first coil to second coil. Hence the first coil is called primary winding and the other coil from which energy is drawn out is called secondary winding.

VOLTAGE TRANSFORMER RATIO (K)

$$K = \frac{V_2}{V_1} = \frac{I_1}{I_2}$$

Where k is known voltage transformation ratio. When $k > 1$ the transformation is called as step up transformer. When $k < 1$ the transformer is called as step down transformer.

DIAGRAM:

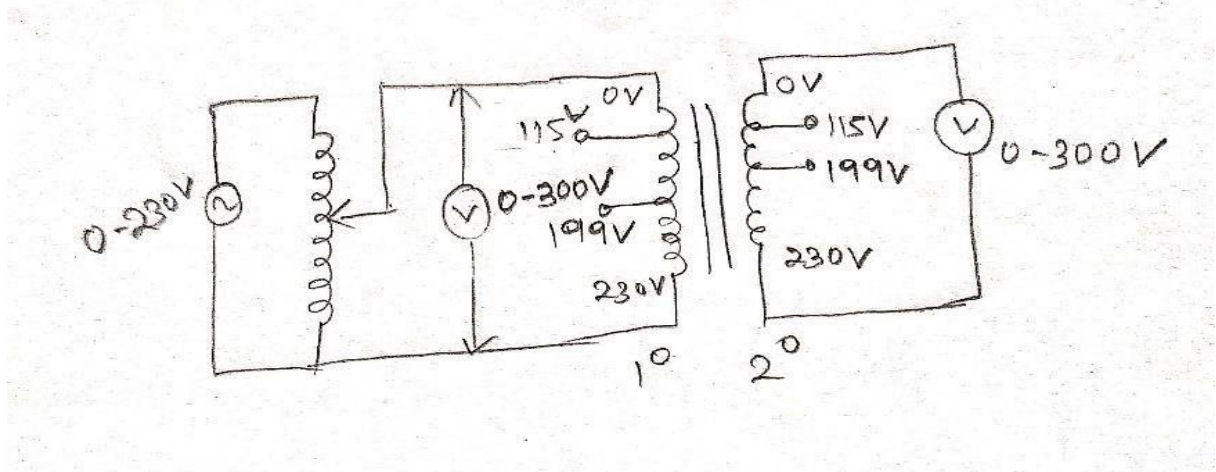

PROCEDURE:

OBSERVATION TABLE:

SL. NO.	PPRIMARY VOLTAGE (V ₁)	SECONDARY VOLTAGE (V ₂)	K=	REMARK
1				
2				
3				
4				

CONCLUSION:

DISCUSSION QUESTION:

1. What is transformer?
2. What are the different types of transformer?
3. What is step up and step down transformer?
4. What is the condition in case of ideal transformer?

EXPERIMENT- 7(A)

AIM OF THE EXPERIMENT:

Open circuit test of a single phase transformer.

EQUIPMENT REQUIRED

Sl no.	Name	Specifications	Quantity
1	Single phase transformer	1KVA, 0-11A, 5-199-230V, 50Hz	1no
2	Variac	0-270V	1no
3	Voltmeter	0-300V	1no
4	Single core copper wire	3/22 swg	As per reqd
5	Wattmeter	(5-10)A, 50Hz, 75-150-300V, $\cos\Phi=0.5$	1no
6	Ammeter	0-2A	1no

THEORY

By the experiment we know the iron loss of a transformer. Iron loss is a constant from no load to full load of a transformer. It depends on the applied voltage. But we can minimize by laminating the core. Core is made up of silicon steel.

$$W = VI_a \cos\Phi$$

V=applied voltage

I_a= no load current

$\cos\Phi$ =power factor at no load condition

DIAGRAM

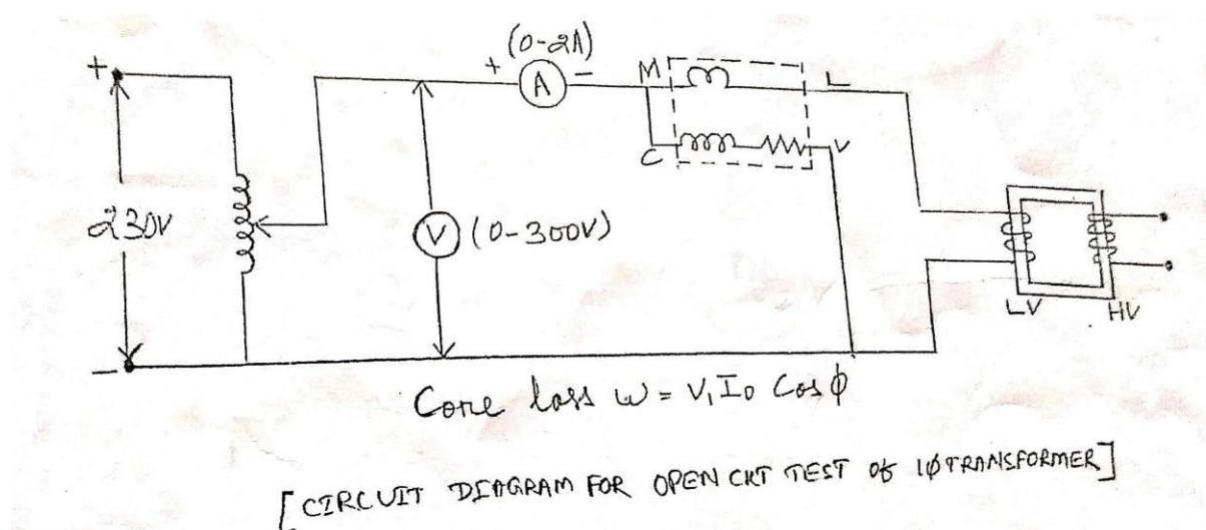

PROCEDURE

- i. The entire instrument should be connected as per circuit diagram.
- ii. Usually the high voltage side is kept open because the voltmeter should be low rating for better use.
- iii. The full load rated voltage is given to the low voltage side.
- iv. The reading of wattmeter will give the iron loss.
- v. Ammeter reading will give the no load

$$\text{current. } W_0 = V_1 I_0 \cos \Phi$$

$$\cos \Phi = \text{no load pf} = W_0 / V_1 I_0$$

$$I_m = \text{magnetising current} = I_0 \sin \Phi_0$$

- vi. A variac was connected to regulated the applied voltage.

CALCULATION

$$I_m = I_0 \sin \Phi_0 \quad X_0 = \frac{V_1}{I_m}$$
$$I_w = I_0 \cos \Phi_0 \quad R_0 = \frac{V_1}{I_w}$$

OBSERVATION:

Sl no.	Wattmeter(W_0)	Ammeter(I_a)	Voltmeter(V_1)	Iron loss	Remark
1					

PRECAUTION:

All the connection should be properly done. Proper terminal should be chosen for open circuit.

The connection should be perfect and tight.

CONCLUSION:

DISCUSSION QUESTION:

1. Why transformer rating is in KVA?
2. What are losses occur in a transformer?
3. Mention the factor on which hysteresis loss depends?
4. What is eddy current losses and how can eddy current loss is minimized?

EXPERIMENT- 7(B)

AIM OF THE EXPERIMENT:

Short circuit test of a single phase transformer.

EQUIPMENT REQUIRED

Sl no.	Name	Specifications	Quantity
1	Single phase transformer	1KVA, 0-115-199-230V, 50Hz	1no
2	Variac	0-150-300V	1no
3	Multimeter	DM-352, 10A, 1000V	1no
4	Connecting wire	3/22swg	As per reqd
5	Wattmeter	(0-15)A, (75-150-300)V, 50Hz	1no
6	AC ammeter	0-5A	2nos

THEORY:

From this experiment we can know that the copper loss of a single phase transformer. Copper loss $W = I^2R$

Where W = wattmeter reading

I = current flowing in the winding

R = resistance of winding

It is variable loss which is proportional to current. It happen in winding of the transformer in the form of heat.

DIAGRAM:

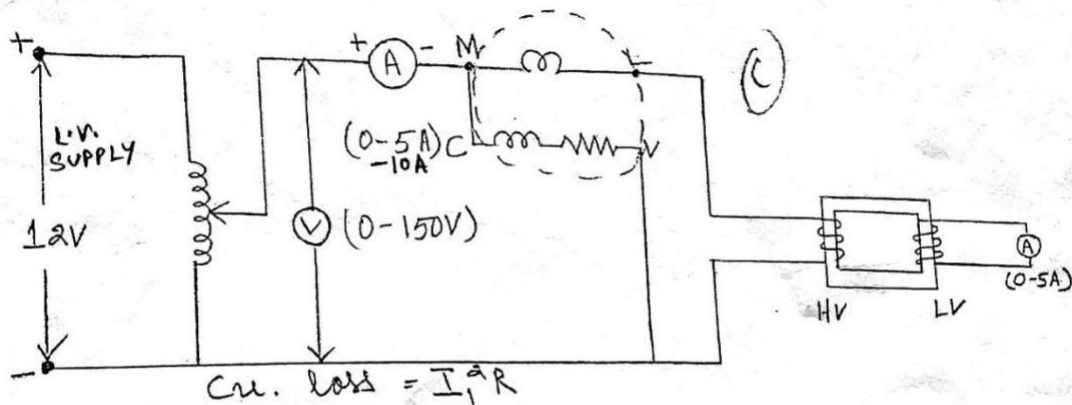

[CIRCUIT DIAGRAM FOR SHORT CKT TEST OF 1 ϕ TRANSFORMER]

PROCEDURE:

1. Before short circuit test of the transformer the low voltage side is short circuited.
2. (5-10)% of normal primary voltage is applied and the reading of ammeter is observed. Whenever it reaches the full load current stop increasing the primary voltage.
3. Ammeter, voltmeter, & wattmeter are connected on the high voltage side.
4. Since in this test the applied voltage is a small percentage of normal voltage, the mutual flux produced is also a small percentage of its normal value. Hence core losses are very small with the result that the wattmeter reading represent the full load copper loss or I^2R loss for the whole transformer.

OBSERVATION:

<u>Sl no</u>	<u>Primary voltage</u>	<u>Primary current</u>	<u>Secondary current</u>	<u>Wattmeter reading</u>	<u>Copper loss</u>
1					

PRECAUTION:

1. The connection should be perfect and tight.
2. Proper terminal should be chosen for short circuit.

CONCLUSION:**DISCUSSION QUESTION:**

1. What is power factor?
2. What is purpose of performing open circuit test & short circuit test on a transformer?
3. What is all day efficiency?

EXPERIMENT NO: 8

AIM OF THE EXPERIMENT:

Determine voltage regulation of single phase transformer by direct loading.

EQUIPMENT REQUIRED:

Sl no	Name of equipment	Specification	Quantity
1	Variac	(0-270)V, 5A	1no
2	Single phase transformer	1KVA, 0-11A, 5-199-230V, 50Hz	1no
3	Voltmeter(AC)	0-300V	2nos
4	Single core copper wire	3/22swg	As per reqd
5	Rheostatic load	0-2500watt	1no
6	Ammeter(AC)	0-5A	1no

THEORY:

Transformer is an electrical device which transfers electrical power from one circuit to another circuit without changes in frequency. In other words it is static piece of apparatus by means of which electrical power of the same frequency is transfer into another circuit. It accomplish this circuit by electromagnetic induction and the two electric circuit are in mutual inductive influence of each other.

There are two winding in transformer voltage regulation. It is defined as the change in secondary terminal voltage from no load to full load condition. Voltage regulation= $\frac{V_{01}-V_1}{V_{01}}$, where V_{01} =no load secondary voltage. So % of voltage regulation $(\frac{V_{02}-V_2}{V_{02}}) \times 100$

If the regulation of a transformer is in between 5%-10% then the transformer is said to be a good transformer.

DIAGRAM:

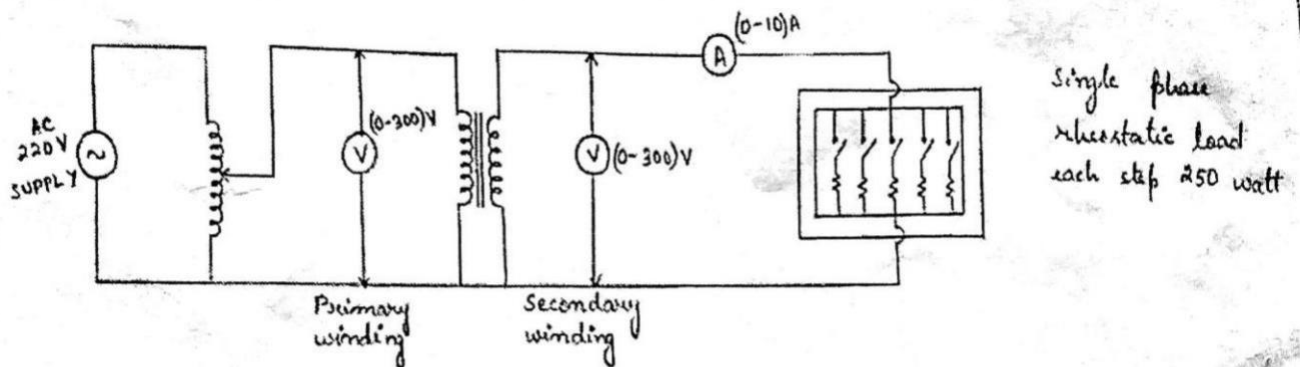

(ckt. dia. for voltage regulation of 1- ϕ transformer)

PROCEDURE:

At first the circuit diagram was studied then connects wire. Connecting wires were connected with variac and the primary of transformer. Secondary winding of transformer was connected to one part of load. Thus connections are so made. At last voltage reading is taken in no load condition. Thus the voltage regulation taken out is in between 5%-10%. Then the transformer is said to be a good condition.

OBSERVATION:

<u>Sl no</u>	<u>Load in watt</u>	<u>No load voltage</u>	<u>Secondary voltage</u>	<u>Secondary current</u>	<u>Regulation $((V_{02}-V_2/V_{02})\times 100)$</u>	<u>Remarks</u>
1	0	220				Good condition
2	250	220				
3	500	220				
4	750	220				
5	1000	220				
6	1250	220				

CONCLUSION:**DISCUSSION QUESTION:**

1. What is the voltage regulation of t/f?
2. Write down types of voltage regulation in t/f?
3. What is need of voltage regulation in t/f?

EXPERIMENT:-9

AIM OF THE EXPERIMENT:

The parallel operation of a single phase transformer.

EQUIPMENT REQUIRED:

<u>Sl no</u>	<u>Name of equipment</u>	<u>Specifications</u>	<u>Quantity</u>
1	Variac	(0-270)V, 5A	1no
2	Single phase transformer	1KVA, (0-230)V, 50Hz	1no
3	Voltmeter(AC)	0-300V	2no
4	Single core copper wire	3/22swg	As per reqd
5	Rheostatic load	0-2500 watt	1no

THEORY:

For supplying a load in excess of the rating of an existing transformer, a second transformer may be connected in parallel. It is seen that primary windings are connected to the supply bus bars and secondary windings are connected to the load bus bars. In connecting two or more than two transformers in parallel, it is essential that their terminals of similar polarities are joined to the same bus bars. If this is not done, the two emf induced in the secondary which are parallel with incorrect polarities, will act together in the local secondary circuit even when supplying no load will hence produced the equivalent of a dead short circuit.

There are certain definite conditions which must be satisfied in order to avoid any local circulating current and to ensure that the transformers share the common load in proportion to their KVA ratings. The conditions are:

1. Primary winding of transformers should be suitable for the supply system voltage and frequency.
2. The transformers should be properly connected with regard to polarity.
3. The voltage rating of both primaries and secondaries should be identical. In other words, the transformers should have same turns ratio i.e. transformation ratio.
4. The percentage impedance should be equal in magnitude and have the same X/R ratio in order to avoid circulating currents and operation at different power factors.
5. With transformers having different KVA ratings, the equivalent impedances should be inversely proportional to the individual KVA rating if circulating currents are to be avoided.

PROCEDURE:

- I. Study the connection diagram first.
- II. Connect the circuit as per circuit diagram.
- III. The transformers should be properly connected with regard to polarity.
- IV. Connect single phase rheostatic load with the secondary windings of parallel connections of transformer.
- V. Then give 230V of AC supply to the primary winding of transformers connected in parallel.

- VI. Then take the wattmeter reading connected in secondary side of parallel connection of transformers in each of 250 watt loading.
- VII. Repeat the above step maximum up to 1500 watt load.

DIAGRAM:

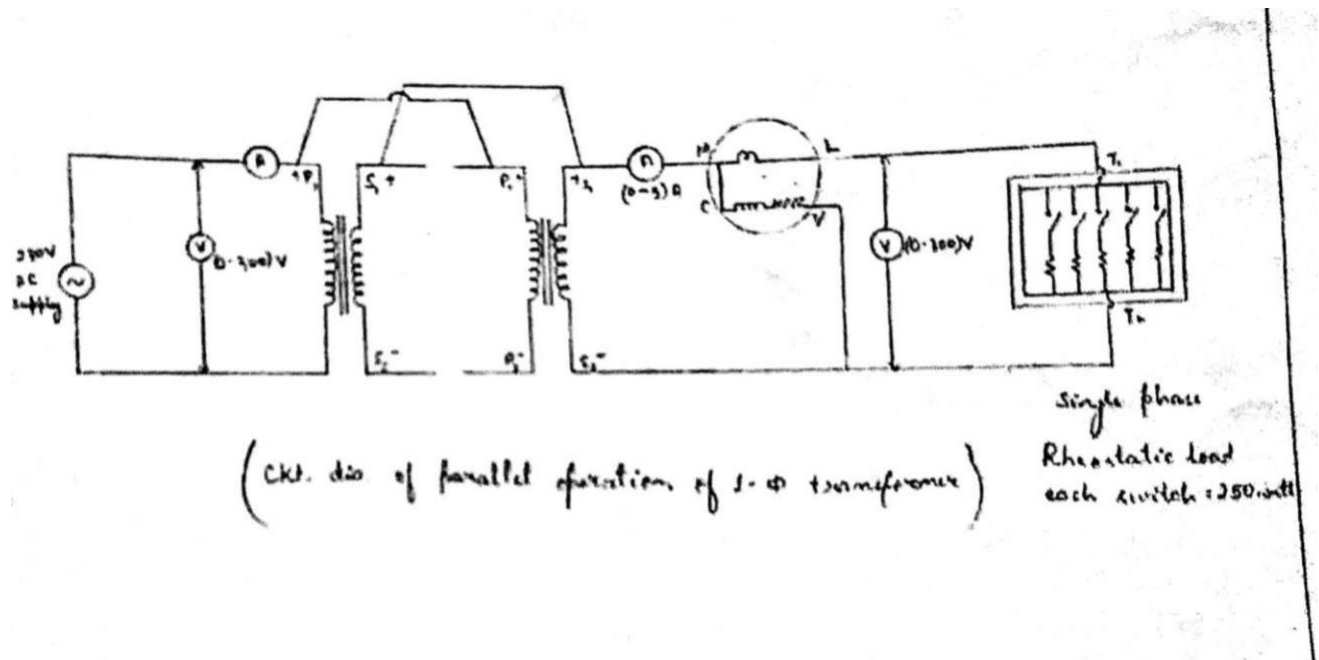

OBSERVATION:

Sl no	Load watt	Primary current (I1)	Load current (I2)	Primary voltage (V1)	Secondary voltage(V2)	o/p power wattmeter reading	Remark
1	250			200			
2	500			200			
3	750			200			
4	1000			200			
5	1250			200			
6	1500			200			

PRECAUTION:

- I. All connection should be proper and tight.
- II. The load should be switched off in steps.
- III. The switch S2 should be opened only after switching off the full load.
- IV. The switch S1 on the primary side should be opened only after opening switch S2 in the other secondary side.

CONCLUSION:

DISCUSSION QUESTION:

- I. What are the conditions of parallel operation of single phase transformer?
- II. What are the advantages parallel operation?
- III. What is load sharing of parallel operation?

EXPERIMENT NO- 10

AIM OF THE EXPERIMENT: Determine the efficiency of a d.c machine by brake test method.

EQUIPMENT REQUIRED:

SL. NO	NAME OF EQUIPMENT	SPECIFICATION	QUANTITY
01.	D.C. series motor	220v; 13.6A; 1450 r.p.m, 3 kw	1 No.
02.	Water cooled	W ₁ -3.230kg; W ₂ -3kg	1 No.
03.	Ammeter	(0-20)A	1 No.
04.	Voltmeter	(0-75-150)v	1 No.
05.	Wire striper	250mm	1 No.

THEORY:

It is the direct method and consists of applying break to a water-cooled pulley mounted on a motor shaft. As shown in the fig. the break band is fixed with the help of the wooden block creeping the pulley. One end of the band is fix to earth wire spring balance 'S' and other is connected to the such banded band W. the motor is running and local on the motor is adjusted till it carries its full load current with the help of switches. Visually the force tangentially on the pulley = difference between the reading of the two spring balances.

If R is pulley radius the torque at the pulley is $T_{sh} = (s_1 - s_2)R$.

If $w = 2\pi N$ is the angular velocity of the pulley then, motor output = $T_{sh} \times w = 2\pi N (s_1 - s_2)$

$2\pi N(s_1 - s_2)R$ meter kg wt = $9.81 \times 2\pi N(s_1 - s_2)R$ watt.

Efficiency may as usual, be found by using the relation.

$$\eta = \frac{P_o}{P_i}$$

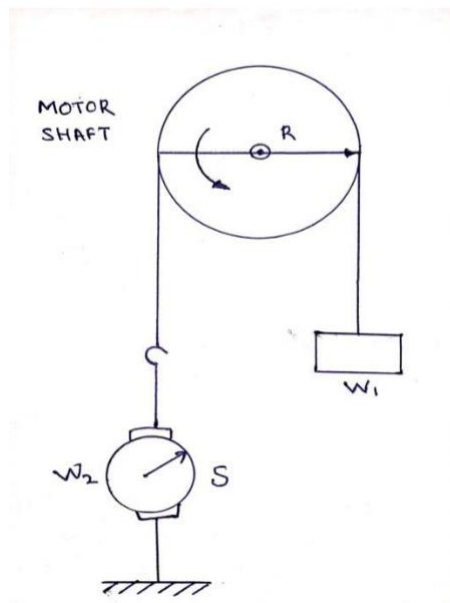

PROCEDURE :

1. At first we measured the radius of water cooled pulley.
2. We connected the ammeter in series and voltmeter in parallel with the terminal of armature A₁ and A₂ as per diagram.
3. After connection we checked the connection perfectly and run the motor with the help of 2-point starter and measured the speed of motor by the tachometer.
4. After measured the speed of motor, we off the supply and stopped the practical.
5. After that we put the value of W₁, W₂, R, N, V and I in the formula and found but the efficiency of d.c machine.
6. The efficiency of motor was found out about 86.8%.

OBSERVATION:

$$R= 6\text{cm}=0.06\text{m}$$

$$W_1=3.230\text{kg}$$

$$W_2=1.2\text{kg}$$

$$I=10.8\text{A}$$

$$V=170\text{v}$$

$$N=780 \text{ r.p.m}=780/ 60=13 \text{ r.p.s}$$

$$\eta\% = \frac{61.68(4-2)}{6.68(1-2)} \times 100$$

$$\eta\% = \frac{61.68(3.230-1)}{6.68(3.230-1)} \times 100 = 86.8\%$$

CONCLUSION:

DISCUSSION QUESTION:

1. How to determine the efficiency of d.c machine by break test method?
2. What is the working principle of d.c shunt motor?
3. What are the types of d.c generator?
4. Explain the condition for parallel operation of generator?